

2020-02-19

Convergent Effect of Work Family Conflict on Job Satisfaction of commercial Banks Employees in Bangladesh: does gender role moderate the effect?

Uddin, Mohammad Jamal

<http://ar.iub.edu.bd/handle/11348/456>

Downloaded from IUB Academic Repository

**CONVERGENT EFFECT OF WORK-FAMILY CONFLICT ON JOB
SATISFACTION OF COMMERCIAL BANK'S EMPLOYEES IN BANGLADESH:
DOES GENDER ROLE MODERATE THE EFFECT?**

Mohammad Jamal Uddin*
Metropolitan University

Mohammad Mizanur Rahman
Faculty of Economics and Management, Universiti Putra Malaysia

Md. Saidur Rahaman
Metropolitan University

ABSTRACT

Work and family are two domains of extraordinary importance in the lives of the most men and women in our society. Today's highly demanding nature of work and family has given rise to conflicting relations. The present study has explored the effect of Work-Family Conflict (W-FC) on employee's job satisfaction of commercial banks in Bangladesh. Convenience sampling method has been used for this research. A sample of 216 respondents from different commercial banks in Bangladesh has been used in the study. Different statistical measures such as descriptive statistics, zero-order correlation, Confirmatory Factor Analysis (CFA) and multiple regression analysis have been used to explore the convergent effect of WFC/FWC on the job satisfaction and other research observations. Results of the study confirm a significant negative relationship between work-family conflict and job satisfaction; and family work conflict does not relate to job satisfaction significantly. Though the FWC has also a negative effect on job satisfaction but it was insignificant. Finally, the gender role (male and female) does not moderate any of the relationships between WFC and job satisfaction; FWC and job satisfaction. This study suggests that the policymaking authority of banking sector should initiate necessary measures to keep work-family conflict strain at a minimum to bring employee satisfaction at work.

Keywords: Commercial Banks, Work-Family Conflict, Family-Work Conflict, Job Satisfaction.

Corresponding author

Mohammad Jamal Uddin* Email: muddin@metrouni.edu.bd



INTRODUCTION

Work and family are the two most important elements of an adult individual's life. An individual has to play multiple responsibilities relating to work and family that require a great amount of time and energy. Simply, imbalance of the multiple roles across the two domains (family and work) is the outcome of the work-family conflict. Work-family conflict denotes a reciprocal relationship between work and family, with work affecting family negatively i.e., work-to-family conflict (Nelson et al. 2012; Minnotte et al., 2013, 2015), and family affecting work negatively (i.e., family-to-work conflict) (Voydanoff, 2007; Hill 2005). Research shows that work-family conflict consists of a two-dimensional construct: where first dimension (work-to-family conflict) specifies the conflict arising work roles interfere with family roles and the second dimension (family-to-work conflict) refers to the conflict arising when family roles interfere with work roles (Beutell, 2010; Kinnunen et al., 2010; Kossek et al., 1998). Past research posited that the effect of work-family conflict is related to increased turnover intentions, parental distress; and reduced job satisfaction, organizational commitment and family satisfaction (Beutell, 2010; Kinnunen et al., 2010; Lu et al., 2010; Karatepe et al., 2007; Spector et al., 2007; Kossek et al., 1998). The effect of work-family conflict on job satisfaction and other related variables, has been widely explored among employees in lieu of a variety of occupations such as hotel employees, social workers, college professors, software workers, etc. (e.g. Karatepe et al., 2007; Namasivayam et al., 2007; Grandey et al., 2005; Scholarios et al., 2004). Nevertheless, the effect of work-family conflict on various individual and organizational outcomes among bank's employees' remains relatively unexplored, particularly in the Bangladeshi context. There are 56 private commercial banks in Bangladesh operating under different ownerships system and almost all banks serve their operations through branch banking system (Uddin et al., 2014). Virtually, we know that bank organizations a labor-intensive competitive service sector in Bangladesh (Rahman et al., 2013). The success and failure of a banking organization as a service sector to a large extent depend on employee efforts, job satisfaction, integrity and commitment (Uddin et al., 2014). Officially, employees in Bangladesh are usually required to work six to eight hours in a working day and for banking organization, it is 10.00 am-6.00pm. Bank officials and employees (including female staff) are unnecessarily told to stay in the office on the pretext of work even after the close of banking hours at 6:00 pm. This is not humane, said the former governor of Bangladesh Bank Mr. Atiur Rahman at a meeting with chief executives of all banks operating in Bangladesh.

This excessive workload and career pressure force them to stay for an extra time in the bank and sometimes take away the work assignment to home. So, there might be a limited time and energy (physical, emotional and psychological) to devote to family. This disparity of resource allocation between work life and family life cause to create work-family conflict. Demographic variables like gender, age, marital status, employment

nature, experience have made work-family integration as a crucial issue for everyone (Aryee et al., 2005; Lewis et al., 1999). In developing countries like India, Bangladesh, the demographic changes are seen as factors for increasing number of women in the workforce and increasing number of nuclear as well as dual-earner families (Buddhapriya, 2009; Bharat, 2003; D'Cruz et al., 2001; Rajadhyaksha et al., 2000). These demographic variables have put considerable pressure on both men and women to concurrently manage their work and family obligations. In order to better understand this phenomenon, the present study aims to investigate the convergent effect of work-family conflict (work-to-family conflict and family-to-work conflict) on job satisfaction among banks employees' in Bangladesh in consideration of gender role differences.

OBJECTIVES OF THE RESEARCH

The fundamental objective of this research is to find out the convergent effect of work-family conflict on job satisfaction among bank employees in Bangladesh. In order to emerge the fundamental objective, the researchers intended to set the following objectives:

- To establish the causal relationship between work-family conflict/family-work conflict and job satisfaction.
- To know whether the bank employees gender difference moderates the relationship between work-family conflict/family-work conflict and job satisfaction.

LITERATURE REVIEW

Work-Family Conflict

The concept of work-family conflict has initially been explained by Kahn et al., (1964) using the role theory framework. It is happened due to the role disparity between the work life and family life. Work-family conflict, thus, refers to the bidirectional construct i.e. the work roles interfere the family roles i.e., work-family conflict; and the family roles interfere the work roles i.e., family work conflict (Judge et al., 2006; Grandey et al., 2005; Netemeyer et al., 1996; Frone et al., 1992; Coverman, 1989). While, Greenhaus and Beutell (1985) defined that work-family conflict as a form of inter-role conflict, which describes the discrepancy between the roles of work and family domains and it is dimensioned as time-based work-family conflict, strain-based work-family conflict and behavior based work-family conflict (Michel et al., 2011; Byron, 2005; Greenhaus et al., 1985).

Job Satisfaction

Due to the impact on individuals and organizations, job satisfaction is one of the important research issues (Lu et al., 2012) which has been researched more than any other variable in Organizational Behavior (Abdulla et al., 2011). Hartline and Ferrell (1996), Brief (1998) defined job satisfaction to be an organization of mind in which an individual can display with some level of like or dislike and evaluate one's job. On the other hand, Tett and Meyer (1993) believed that job satisfaction as an emotional attachment to the complete job (comprehensive perspective) or a certain part of the job (partial perspective) of an individual. Job satisfaction has been found to significantly impact on individual and organizational performance such as absenteeism, turnover, and employee relations (Ajmi, 2001; Scarpello et al., 1983) and employee health and well-being (Khaleque, 1981). While, if the employees are dissatisfied they are disposed to extreme absenteeism and turnover (Metle, 2003, 2002; Koys, 2001), but, satisfied employees are more likely to be effective in handling daily stressors and less likely to be absent or withdraw from their work (Zeffane et al., 2008)

THEORETICAL RESEARCH FRAMEWORK AND HYPOTHESIS DEVELOPMENT

The researchers owing to support of theoretical and contextual foundations, intend to establish the causal relationship between direction specific work-family conflict and employee job satisfaction. Gender position here assumed plays a significant role in these causal relationships. Accordingly, we supposed to design an operational research framework presented in figure no.I which helps to construct hypotheses that determine the causal relationships among studied variables.

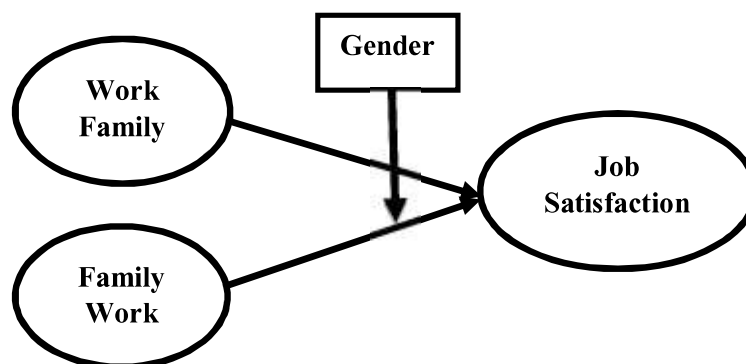

Figure-I: Theoretical Framework of Work Family Conflict and Job

Work-Family Conflict and Job Satisfaction Relationship

To find out the relationship and effect of work-family conflict on employees' job satisfaction, several types of research have been conducted in the disciplines of sociology, psychology and management (Martins 2002; Miller et al., 2000; Conger et al., 1999; Livingston and Burley 1996). Job satisfaction as an enjoyable emotional state that results from an individual appraisal of one's job" (Locke, 1969). It has been observed from several previous research that job satisfaction is the cause of many favorable organizational outcomes, such as lower absenteeism, turnover rate and increased job performance, organizational commitment (Kinicki et al., 2002; Judge et al., 200;). In an organization, there are a number of factors responsible for bringing and eroding employee satisfaction at work. Research on WFC/FWC pointed out WFC as antecedents of reducing employee job satisfaction (Karatepe et al., 2007; Spector et al., 2007; Karatepe et al., 2006). The findings of the previous researchers indicate that work-family conflict is negatively associated with job satisfaction (Beutell, 2010; Karatepe et al., 2007; Spector et al., 2007; Karatepe et al., 2006). Michel et al., (2009) conducted a meta-analysis to test the work-family conflict models and reported a negative relationship between work-family conflict and job satisfaction. Based on the aforesaid literature the researchers formulated the following hypothesis:

Hypothesis H₁: *Work-family conflict has a negative effect on job satisfaction.*

Family Work Conflict and Job Satisfaction Relationship

Recently many scholars have analyzed the relationships between both directions of work-family conflict (work-to-family conflict and family-to-work conflict) and job satisfaction based on time, strain and behavior. Bartolome (1972) believed that employees experienced two aspects that could not be coordinated with each other even it can be difficult to give consideration to both aspects at the same time. However, a number of studies have shown regarding the relationship between family-work conflicts on job satisfaction and found a negative influence on job satisfaction (Boyar et al., 2007; Lu et al., 2009). Again, most of the researchers (Thanacoody et al., 2009; Lu, et al., 2008; Yildirim et al., 2008; Karatepe et al., 2007; Namasivayam et al., 2007; Karatepe et al., 2006; Lu et al., 2006; Menguc et al., 2005; Eby et al., 2005; Howard et al., 2004; O'Driscoll et al., 2004; Wayne et al., 2004; Bruck et al., 2002) examined by many and their outcome is job dissatisfaction as one of the common consequences of family-work conflict. Based on the aforesaid literature the researchers formulated the following hypothesis:

Hypothesis H₂: *Family work conflict has a negative effect on job satisfaction.*

Gender Role in the relationship between Work-Family Conflict/ Family-Work Conflict and Job Satisfaction

Based on the two theories named role identity salience theory and the gender role theory, Ford et al. (2007) proposed that the gender differences may moderate the effect size of work-family conflict on job satisfaction. So, the magnitude of the relationship between work-family conflict and job satisfaction may be moderated by the salience of the family role identity as opposed to the work role for each gender. Although there are very few studies that have taken on the proposition set by Ford et al. (2007) and found inconsistent results. Noor (2004), in a sample of women, found no significant moderating effects of the salience of the family role on the relationship between work-family conflict and job satisfaction. Following the above literature, the researchers construct the hypothesis:

Hypothesis H₃: *Employee gender moderates in the relationship between work-family conflict/ family-work conflict and employee job satisfaction*

METHODOLOGY

Sample and Procedure

The respondents of this research are the employees working in public and private banks in Bangladesh. Structured close-ended questionnaire packages have been used and sent to collect the data. Questionnaires have been developed in both English and Bengali language. Here, work-family conflict and family work conflict variables are taken as independent variables, Job satisfaction as dependent variable and gender acts as the moderating variable. Convenience sampling method had been used for this research. At the first time, the questionnaire had been administered to 30 employees of private and public banks for a pilot study to investigate the validity of all questions. Results have shown good reliability except for minor change. On the basis of pilot study's feedback, the final questionnaire has been modified and finalized to collect primary data. 309 survey questionnaires were distributed and 225 (72.81% response rate) questionnaires returned. However, 09 filled questionnaires were discarded because the respondents served either inconsistent information or missing data. This study is based on 216 full-time banking employees.

Participants

In the study sample, it has found that 26% respondents are male while 74% are female. Among them, 95% respondents are married, and 5% respondents are unmarried. Maximum (41.9%) banking employees were at the age of 35⁺ years but in terms of job experience, 47% respondents having 1- 10 years. 57% respondents stay with parents and 43% live as a nuclear family; 17.6 % working at public banks and 82.4% working at private banks.

Measures with Unidimensionality and Validity

The independent variables have been measured by two subscales named work-family conflict (9 items) and family work conflict (9 items) such as, "The time I devote to my job keeps me away from participating household responsibilities"; "When I get work from home, I am often too frazzled to participate in job responsibilities". Job satisfaction has been measured by 6 items such as "I find real enjoyment in my job". Response options ranged from (1) "Strongly Disagree" to (5) "Strongly Agree". Unidimensionality will be achieved when the factor loading for each item will be higher than 0.5 (for newly develop scales) and 0.6 (for established scales) (Zainudin, 2012). In this research, the measuring items for work-family conflict, family work conflict, and job satisfaction have an acceptable factor loading (above 0.6). The figure with a factor loading of each construct is given below:

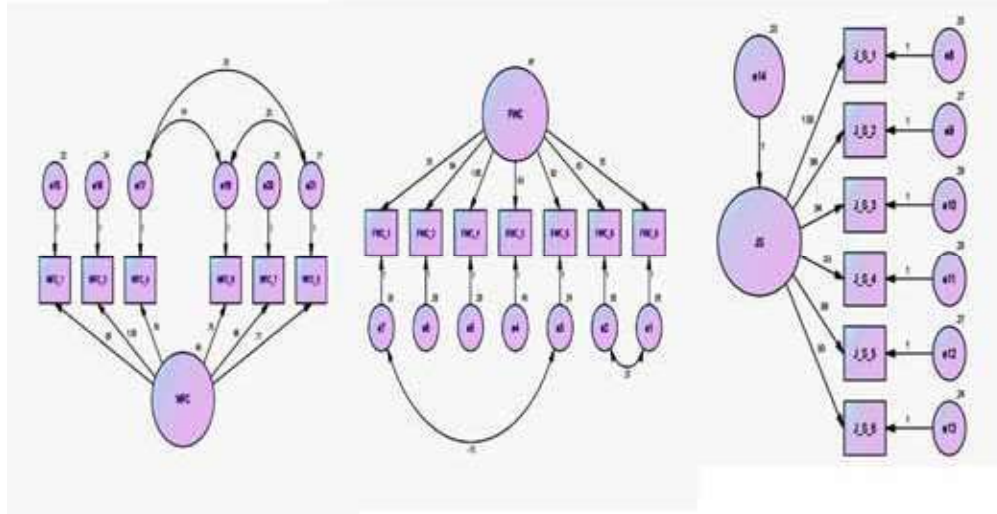

Fig. II: Unidimensionality for WFC

Fig. III: Unidimensionality for FWC

Fig. IV: Unidimensionality for JS

Three types of validity (convergent, construct and discriminant validity) have measured in this research paper. Convergent validity was achieved when all the items in the measurement model such as work-family conflict, family work conflict, and job satisfaction were statistically significant and the AVE (Average Variance Extracted) was greater than 0.5. Construct validity was achieved when the Fitness Indexes achieved the requirements; GFI>0.9, CFI>0.9, RMSEA≤0.085 and the ratio of Chi sq/df was less than 5.00.

Table I: Fit Indices for Work-Family Conflict, Family-Work Conflict, and Job Satisfaction

		Work Family Conflict	Family Work Conflict	Job Satisfaction
Absolute fit	RMSEA	0.037	0.055	0.060
	GFI	0.988	0.982	0.980
Incremental fit	AGFI	0.959	0.954	0.954
	CFI	0.988	0.966	0.966
Parsimonious fit	Chisq/df	1.302	1.65	1.45

Source: from the data analysis in AMOS

Discriminant validity was achieved when the measurement model for work-family conflict, family work conflict, and job satisfaction was independent of the redundant items. The other requirements for discriminant validity were achieved when the pattern structure correlation between a pair of the latent exogenous construct was less than 0.85.

Measures with Reliability

Table II: Measures of Reliability

Construct	Items	Factor Loading	Cronbach Alpha
Work Family Conflict	WFC_3	.789	0.872
	WFC_1	.784	
	WFC_4	.766	
	WFC_7	.761	
	WFC_8	.760	
	WFC_6	.733	
	WFC_5	.610, This item was deleted due to low factor loading	
	WFC_2	This item was deleted due to low factor loading	
	WFC_9	This item was deleted due to low factor loading	
Family Work Conflict	FWC_4	.766	0.807
	FWC_3	.752	
	FWC_8	.667	
	FWC_6	.659	
	FWC_1	.641	
	FWC_5	.624	
	FWC_9	.616	
	FWC_2	This item was deleted due to low factor loading	
	FWC_7	This item was deleted due to low factor loading	
Job Satisfaction	J_S_1	.751	0.824
	J_S_2	.740	
	J_S_6	.737	
	J_S_4	.721	
	J_S_3	.719	
	J_S_5	.706	

Source: from the data analysis in AMOS

Plan for Analysis

Using AMOS and SPSS software, data analyses have been carried out. First, means, standard deviations, and correlations were computed for all independent and dependent variables to assess the general pattern of relationships among predictors and predicted variables and to provide support to regression results. Descriptive and inferential statistics including mean, standard deviation (SD), reliability, and correlation analysis were executed using SPSS. Meanwhile, AMOS was executed to analyze confirmatory factor analysis (CFA) and direct effects analysis for purpose of examining the constructs validity and regression result for the direct effect of work-family conflict on job satisfaction. Finally, using SPSS and free online calculator for comparing two regression coefficients to know the moderating effect of gender on the relationship between work-family conflict and job satisfaction.

ANALYSIS AND RESULTS

Table III: Descriptive and Correlation Analysis

	Mean	SD	Job Satisfaction	Work-Family Conflict	Family Work Conflict
Job Satisfaction	3.67	.50	1		
Work Family Conflict	2.96	.63	-.297**	1	
Family Work Conflict	2.56	.56	-.243**	.598**	1

Source: from the data analysis in SPSS

Table III presents descriptive statistics of mean, standard deviation and correlation between variables of the study. The result indicated that job satisfaction ($m=3.67$, $SD=\pm 0.50$) were high. And the mean and standard deviations of work-family conflict ($m=2.96$, $SD=\pm 0.63$) and family work conflict ($m=2.56$, $SD=\pm 0.56$) were in moderate level. Correlation analysis showed that both work-family conflict ($r=-.297$, $p<0.00$) and family work conflict ($r=-.243$, $p<0.00$) have a negative correlation with job satisfaction. Result emphasized that high-level work-to-family conflict leads to decreasing level of job satisfaction among banking employees. But, if we compare between work-family conflict and family work conflict then the work-family conflict has the highest correlation with job satisfaction.

CONFIRMATORY FACTOR ANALYSIS (CFA) AND DIRECT EFFECT RESULT

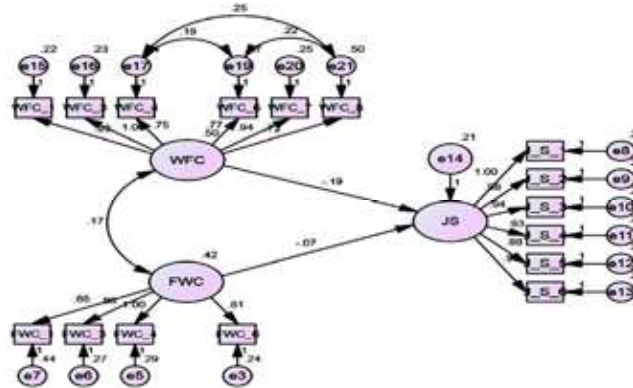

Fig V: Confirmatory Factor Analysis (CFA) and Direct Effect Result

Table IV: Fit Indices for overall Measurement Model

Absolute fit	RMSEA	: 0.028
	GFI	: 0.940
Incremental fit	AGFI	: 0.917
	CFI	: 0.997
Parsimonious fit	Chisq/df	: 1.169

Source: from the data analysis in AMOS

Table V: Result of the Effect of Work-Family Conflict on Job Satisfaction

			Estimate	S.E.	C.R.	P
Job Satisfaction	<---	Family Work Conflict	-.073	.066	-1.104	.269
Job Satisfaction	<---	Work Family Conflict	-.192	.061	-3.155	.002

Source: from the data analysis in AMOS

Figure V and Table V indicate the direct effect model for model fit indexes regression weights for work-to-family conflict and job satisfaction. It was found that the overall model has yielded good fit with data $\chi^2/df=1.169$, RMSEA=0.028, CFI=0.997, GFI=0.940

and AGFI=.917. Overall, both work-family conflict and family work conflict explained 21% variance in job satisfaction ($R^2=0.21$). Regression results indicated that only work-family conflict has a significant negative effect on job satisfaction ($\beta= -.192$, $p<0.002$). The family work conflict has a negative effect on job satisfaction ($\beta= -.073$, $p<0.269$) but insignificant. Results suggested that increasing level of work-family conflict capital was associated with decreasing level of job satisfaction. Therefore, only hypothesis H_1 has got support and hypothesis H_2 has not got support.

MODERATING EFFECTS: GENDER AS MODERATOR IN THE RELATIONSHIP BETWEEN WORK-FAMILY CONFLICT AND JOB SATISFACTION

To find out the moderating effect of gender on the relationship between work-family conflict and job satisfaction, the researchers have split the SPSS file into two groups (male and female) and conducted the multiple regression. The output (only coefficient) table of multiple regression automatically splits into the male and female group, which is given below:

Table VI: Data for Online Calculator for Comparing Two Regression Coefficients

Data for online calculator (Work-Family Conflict and Job Satisfaction)				Data for online calculator (Family Conflict and Job Satisfaction)			
Gender	Model	Unstandardized Coefficients		Gender	Model	Unstandardized Coefficients	
		B	Std. Error			B	Std. Error
Female	(Constant)	4.730	.354	Female	(Constant)	4.668	.378
	WFC	-.324	.115		WFC	-.342	.139
Male	(Constant)	4.347	.184	Male	(Constant)	4.283	.186
	WFC	-.242	.062		WFC	-.248	.071

Source: from the data analysis in AMOS

Now, the researchers used an online calculator for comparing two regression coefficients (<http://www.danielsoper.com/statcalc/calculator.aspx?id=103>) to know the moderating effect of gender on the relationship between work-family conflict and job satisfaction. This calculator has determined whether the effects of gender are significantly different from each other. Putting the necessary information from the coefficient table (beta, standard error, and sample size) into the online calculator and the results of the online calculator are given below:

Table VII: The t-test Results for Moderating Effect

Results of online calculator for work-family conflict and job satisfaction		Results of online calculator for family work conflict and job satisfaction	
t-Value	:0.765	t-Value	:0.602
Degrees of freedom	:212	Degrees of freedom	:212
Probability (p)	:0.444	Probability (p)	:0.547

Source: from the data analysis in Online Calculator

From the coefficient table for work-family conflict the B = -.324 for female and B = -.242 for male and for family work conflict the B = -.3424 for female and B = -.248 for male. Though the effect size is different for female and male, the probability value of work-family conflict (0.444) and family-work conflict (0.547) indicate that the gender (male and female) does not moderate the relationship between work-family conflict and job satisfaction. Thus, the hypothesis H₃ has not got support.

OVERALL DISCUSSIONS

This study examined the relationship and effect of work-family conflict (W-FC) on job satisfaction among banking employees in Bangladesh. The findings showed that W-FC is significantly and negatively correlated with job satisfaction. These findings are consistent with earlier studies by Zulfiqar et al. (2013), Buonocore et al., (2013), Burke et al. (2013) and Huffman et al. (2014) who reported high WFC conflict is the cause of low job satisfaction. Panatik et al. (2012) also showed a negative correlation between work-to-family conflict and job satisfaction. WFC initially is a psychological event that appears physically in our behaviors in different fashions. As a psychometric phenomenon, WFC affects employees in their performance, commitments, involvements, job satisfaction and even job burnout (Robinson et al., 2016; Montgomery et al., 2006). Thus, work-family friendly policy should be the important consideration of employer HR issues to keep employee WFC at a minimum. This study tested the effect of WFC on job satisfaction and found that the WFC explained by 21% variance in job satisfaction and the effect size was $\beta = -0.19$. The bank HR policy essentially should incorporate some measures to alleviate employee WFC as it closely connected to job satisfaction which in turn allied with turnover intention, employee productivity, and commitment. This study has found no moderating role of gender (male and female) in the relationship between work-family conflict and job satisfaction. These findings are also smaller to the past research findings by Ford et al. (2007), Noor (2004). Findings assert that both the male and female

personnel similarly affected by WFC issues in relation to job satisfaction. Therefore, bank HR policy concerning work-family issues considers both male and female employees.

IMPLICATIONS OF THIS RESEARCH

The findings of the present study have certain implications for employees as well as for banking organizations. The results of the current study indicate that work-family conflict is negatively related to job satisfaction. Previous research has shown that work-family conflict has harmful consequences for employees as well as for organizations (e.g. Beutell, 2010; Kinnunen et al., 2010; Lu et al., 2010; Spector et al., 2007; Grandey et al., 2005). On the other hand, job satisfaction has been observed to produce many desirable organizational outcomes (Kinicki et al., 2002; Judge et al., 2001). So, a banking organization should adopt measures that can reduce work-family conflict and enhance job satisfaction. Generally, banking organizations require employees to work longer hours, even on weekends and holidays (Saturday). This creates work-family conflict, which further leads to job dissatisfaction. It may be suggested that higher authorities in banking organizations should take necessary action to minimize the work-family conflict experienced banking employees so that employees of banking organizations can get sufficient time for their wife/husband, children, and other family members, and can fulfill their family and social responsibilities.

LIMITATIONS AND FUTURE DIRECTION

The researchers acknowledge some limitations and recommend some future directions in connection with this study. The first limitation is the nature of picking up respondents i.e., unequal male (26%) and female (74%) samples size. In the vicinity of male and female samples size will be explored the better moderating role of gender. The second limitation is the figure of moderations. Future research on moderating effect by employment nature, job experience and employment level is expected. The third limitation is the inclusion of one job outcome i.e., job satisfaction. Future research is called to focus on other issues like job performance, employee commitment, and organizational productivity as response variables of work-family conflict. Finally, this study was based on cross-sectional survey procedure which limits the ability to make causal assertions regarding the nature of relationships observed. So, the researchers may suggest little regarding the strength of the implementation of these practices and their causal relationships. Future research may be called to use longitudinal study and focus on the dynamic nature of relationships between WFC and job satisfaction.

CONCLUSION

To work in banking organization is regarded as one of the most stressful occupations in the world. Employees in banking organizations have to face a variety of problems in their jobs and work under constant pressure. Moreover, they often experience work-family conflict due to high job demands and the incompatibility felt between the work roles and the family roles. Since work-family conflict has damaging consequences for employees and their organizations, it is imperative for researchers and organizational leaders to understand the nature of the work-family conflict and its impact on employees and their organizations, in diverse occupations and cultures. The present study contributes in this direction by investigating the relationship of work-family conflict with job satisfaction among banking employees in Bangladesh. This understanding may be helpful for the banking organizations to take necessary action in order to alleviate the work-family conflict and its negative consequences.

REFERENCES

- Abdulla, J., Djebarni, R., & Mellahi, K. (2011). Determinants of job satisfaction in the UAE: A case study of the Dubai police. *Personnel review*, 40(1), 126-146.
- Al-Ajmi, R. (2001). The effect of personal characteristics on job satisfaction: A study among male managers in the Kuwait oil industry. *International Journal of Commerce and Management*, 11(3-4), 91-110.
- Aryee, S., Srinivas, E.S., & Tan, H.H. (2005). Rhythms of life: antecedents and outcomes of work-family balance in employed parents. *Journal of applied psychology*, 90(1), 132.
- Beutell, N.J. (2010). Work schedule, work schedule control and satisfaction in relation to work-family conflict, work-family synergy, and domain satisfaction. *Career Development International*, 15(5), 501-518.
- Bharat, S. (2003). Women, work, and family in urban India: Towards new families. *Psychology in human and social development: Lessons from diverse cultures*, 155-169.
- Bhuiyan, S.N., Menguc, B., & Borsboom, R. (2005). Stressors and job outcomes in sales: A triphasic model versus a linear-quadratic-interactive model. *Journal of Business Research*, 58(2), 141-150.
- Boyar, S.L., & Mosley, D.C. (2007). The relationship between core self-evaluations and work and family satisfaction: The mediating role of work-family conflict and facilitation. *Journal of Vocational Behavior*, 71(2), 265-281.
- Brief, A.P., Schuler, R.S., & Van Sell, M. (1981). *Managing job stress*. Little, Brown.

- Bruck, C.S., Allen, T.D., & Spector, P.E. (2002). The relation between work–family conflict and job satisfaction: A finer-grained analysis. *Journal of vocational behavior*, 60(3), 336-353.
- Buddhapriya, S. (2009). Work-family challenges and their impact on career decisions: A study of Indian women professionals. *Vikalpa*, 34(1), 31-46.
- Byron, K. (2005). A meta-analytic review of work-family conflict and its antecedents. *Journal of Vocational Behavior*, 67, 169 – 198.
- Buonocore, F., & Russo, M. (2013). Reducing the effects of work–family conflict on job satisfaction: the kind of commitment matters. *Human Resource Management Journal*, 23(1), 91-108.
- Chughtai, A.A., & Zafar, S. (2006). Antecedents and consequences of organizational commitment among Pakistani university teachers. *Applied H.R.M Research*, 11(1), 39-64.
- Chung, H. (2011). Work-family conflict across 28 European countries: A multi-level approach. In *Work-Life Balance in Europe*, 42-68. Palgrave Macmillan UK.
- D'cruz, P., & Bharat, S. (2001). Beyond joint and nuclear: The Indian family revisited. *Journal of Comparative Family Studies*, 32(2), 167-194.
- Dewra, A. (2015). Work-Family Conflict, Job Satisfaction and General Well-Being of Working Women (Doctoral dissertation, MPUAT, Udaipur).
- Eby, L.T., Casper, W.J., Lockwood, A., Bordeaux, C., & Brinley, A. (2005). Work and family research in IO/OB: Content analysis and review of the literature (1980–2002). *Journal of vocational behavior*, 66(1), 124-197.
- Ernst Kossek, E., & Ozeki, C. (1998). Work–family conflict, policies, and the job–life satisfaction relationship: A review and directions for organizational behavior–human resources research. *Journal of Applied Psychology*, 83(2), 139-149.
- Fagan, C., & Walthery, P. (2011) Job quality and the perceived work-life balance fit between work hours and personal commitments: a comparison of parents and older workers in Europe, in S. Drobnic and A. Guillén (eds.) *Work-life balance in Europe: the role of job quality*, New York: Palgrave Macmillan, 69-94.
- Ford, M. T., Heinen, B. A., & Langkamer, K. L. (2007). Work and family satisfaction and conflict: A meta-analysis of cross-domain relations. *Journal of Applied Psychology*, 92(1), 57-80.
- Gary, H. W., Howard, D., H., & Boles, J.S. (2004). Inter-domain work-family, family-work conflict and police work satisfaction. *Policing: An International Journal of Police Strategies & Management*, 27(3), 380-395.
- Grandey, A., Cordeiro, B., & Crouter, A. (2005). A longitudinal and multi-source test of the work–family conflict and job satisfaction relationship. *Journal of Occupational and Organizational Psychology*, 78(3), 305-323.
- Grönlund, A. (2007). More control, less conflict? Job demand–control, gender and work–family conflict. *Gender, Work & Organization*, 14(5), 476-497.

- Hartline, M., & Ferrell, O. (1996). The Management of Customer-Contact Service Employees: An Empirical Investigation. *Journal of Marketing*, 60(4), 52-70. doi:10.2307/1251901
- Hill, E.J. (2005). Work-family facilitation and conflict, working fathers and mothers, work-family stressors and support. *Journal of Family issues*, 26(6), 793-819.
- Huffman, A.H., Casper, W.J., & Payne, S.C. (2014). How does spouse career support relate to employee turnover? Work interfering with family and job satisfaction as mediators. *Journal of Organizational Behavior*, 35(2), 194-212.
- Huynh, J. Y., Xanthopoulou, D., & Winefield, A. H. (2013). Social support moderates the impact of demands on burnout and organizational connectedness: A two-wave study of volunteer firefighters. *Journal of Occupational Health Psychology*, 18(1), 9-15.
- Iqbal, A. (2010). An empirical assessment of demographic factors, organizational ranks and organizational commitment. *International Journal of Business and Management*, 5(3), 16-27.
- Judge, T.A., Thoresen, C.J., Bono, J.E., & Patton, G.K. (2001). The job satisfaction–job performance relationship: A qualitative and quantitative review. *Psychological Bulletin*, 127(3), 376-407. DOI:10.1037//0033-2909.127.3.376
- Kahn, R. L., Wolfe, D. M., Quinn, R. P., Snoek, J. D., & Rosenthal, R. A. (1964). *Organizational stress: Studies in role conflict and ambiguity*. Oxford, England: John Wiley.
- Karatepe, O.M., & Kilic, H. (2007). Relationships of supervisor support and conflicts in the work–family interface with the selected job outcomes of frontline employees. *Tourism management*, 28(1), 238-252.
- Karatepe, O.M., & Sokmen, A. (2006). The effects of work role and family role variables on psychological and behavioral outcomes of frontline employees. *Tourism management*, 27(2), 255-268.
- Karatepe, O.M., & Tekinkus, M. (2006). The effects of work-family conflict, emotional exhaustion, and intrinsic motivation on job outcomes of front-line employees. *International Journal of Bank Marketing*, 24(3), 173-193.
- Karatepe, O.M., & Uludag, O. (2007). Conflict, exhaustion, and motivation: A study of frontline employees in Northern Cyprus hotels. *International Journal of Hospitality Management*, 26(3), 645-665.
- Kardam, B.L., & Rangnekar, S. (2012). Job satisfaction: Investigating the role of experience & education. *Researchers World*, 3(4), 16.
- Khalique, A. (1981). Job satisfaction, perceived effort and heart rate in light industrial work. *Ergonomics*, 24(9), 735-742.
- Kinicki, A.J., McKee-Ryan, F.M., Schriesheim, C.A., & Carson, K.P. (2002). Assessing the construct validity of the job descriptive index: a review and meta-analysis. *Journal of Applied Psychology*, 87(1), 14-32. DOI: 10.1037//0021-9010.87.1.14

- Kinnunen, U., & Mauno, S. (1998). Antecedents and outcomes of work-family conflict among employed women and men in Finland. *Human Relations*, 51(2), 157-177.
- Kinnunen, U., Feldt, T., Mauno, S., & Rantanen, J. (2010). Interface between work and family: A longitudinal individual and crossover perspective. *Journal of Occupational and Organizational Psychology*, 83(1), 119-137.
- Koys, D.J. (2001). The effects of employee satisfaction, organizational citizenship behavior, and turnover on organizational effectiveness: A unit-level, longitudinal study. *Personnel psychology*, 54(1), 101-114.
- Lewis, S., & Cooper, C. L. (1999). The work-family research agenda in changing contexts. *Journal of Occupational Health Psychology*, 4, 382-393.
- Locke, E.A., 1969. What is job satisfaction?, *Organizational behavior and human performance*, 4(4), 309-336.
- Lu, H., Barriball, K. L., Zhang, X., & While, A. E. (2012). Job satisfaction among hospital nurses revisited: a systematic review. *International journal of nursing studies*, 49(8), 1017-1038.
- Lu, L., Cooper, C. L., Kao, S. F., Chang, T. T., Allen, T. D., Lapierre, L. M., O'Driscoll, M. P., Poelmans, S. A., Sanchez, J. I., & Spector, P. E. (2010). Cross-cultural differences on work-to-family conflict and role satisfaction: A Taiwanese-British comparison. *Human Resource Management*, 49(1), 67-85.
- Lu, L., Gilmour, R., Kao, S. F., & Huang, M. T. (2006). A cross-cultural study of work/family demands, work/family conflict and wellbeing: the Taiwanese vs British. *Career Development International*, 11(1), 9-27.
- Lu, L., Kao, S. F., Chang, T. T., Wu, H. P., & Cooper, C. L. (2008). Work/family demands, work flexibility, work/family conflict, and their consequences at work: A national probability sample in Taiwan. *International Journal of Stress Management*, 15(1), 1.
- Metle, M. A. K. (2002). The influence of traditional culture on attitudes towards work among Kuwaiti women employees in the public sector. *Women in Management Review*, 17(6), 245-261.
- Metle, M. A. K. (2003). The impact of education on attitudes of female government employees. *Journal of Management Development*, 22(7), 603-626.
- Meyer, J. P., Stanley, D. J., Herscovitch, L., & Topolnytsky, L. (2002). Affective, continuance, and normative commitment to the organization: A meta-analysis of antecedents, correlates, and consequences. *Journal of vocational behavior*, 61(1), 20-52.
- Michel, J. S., Kotrba, L. M., Mitchelson, J. K., Clark, M. A. & Baltes, B. B. (2011). Antecedents of work-family conflict: a meta-analytic review. *Journal of Organizational Behavior*, 32, 689-725.

- Michel, J. S., Mitchelson, J. K., Kotrba, L. M., LeBreton, J. M., & Baltes, B. B. (2009). A comparative test of work-family conflict models and critical examination of work-family linkages. *Journal of Vocational Behavior*, 74(2), 199-218.
- Minnotte, K. L., Minnotte, M. C., & Bonstrom, J. (2015). Work-family conflicts and marital satisfaction among US workers: Does stress amplification matter? *Journal of Family and Economic Issues*, 36(1), 21-33.
- Minnotte, K. L., Minnotte, M. C., & Pedersen, D. E. (2013). Marital Satisfaction among Dual-Earner Couples: Gender Ideologies and Family-to-Work Conflict. *Family relations*, 62(4), 686-698.
- Montgomery, A. J., Panagopolou, E., & Meenks M. D. W. E. (2006). Work-family interference, emotional labor and burnout. *Journal of Managerial Psychology*, 21(1), 36-51.
- Mowday, R. T., Porter, L. W., & Steers, R. M. (1982). Employee-organization linkage. *The psychology of commitment absenteeism, and turn over_ Academic Press Inc. London*.
- Namasivayam, K., & Zhao, X. (2007). An investigation of the moderating effects of organizational commitment on the relationships between work-family conflict and job satisfaction among hospitality employees in India. *Tourism Management*, 28(5), 1212-1223.
- Nelson, C. C., Li, Y., Sorensen, G., & Berkman, L. F. (2012). Assessing the relationship between work-family conflict and smoking. *American journal of public health*, 102(9), 1767-1772.
- Noor, N. M. (2004). Work-family conflict, work-and family-role salience, and women's well-being. *The Journal of social psychology*, 144(4), 389-406.
- O'Driscoll, M. P., Brough, P., & Kalliath, T. J. (2004). Work/family conflict, psychological well-being, satisfaction and social support: A longitudinal study in New Zealand. *Equal Opportunities International*, 23(1-2), 36-56.
- Pleck, J. H., Staines, G. L., & Lang, L. (1980). Conflicts between work and family life. *Monthly Labor Review*, 103, 29-32.
- Rajadhyaksha, U., & Bhatnagar, D. (2000). Life role salience: A study of dual-career couples in the Indian context. *Human Relations*, 53(4), 489-511.
- Robinson, L. D., Magee, C. A., & Caputi, P. (2016). Work-to-family profiles, family structure and burnout in mothers. *Journal of Managerial Psychology*, 31(7), 1167 – 1181.
- Rupert, P. A., Stevanovic, P., Hartman, E. R. T., Bryant, F. B., & Miller, A. (2012). Predicting work-family conflict and life satisfaction among professional psychologists. *Professional Psychology: Research and Practice*, 43(4), p.341.
- Salami, S. O. (2008). Demographic and psychological factors predicting organizational commitment among industrial workers. *Anthropologist*, 10(1), 31-38.

- Scarpello, V., & Campbell, J. P. (1983). Job satisfaction: Are all the parts there? *Personnel psychology*, 36(3), 577-600.
- Scholarios, D., & Marks, A. (2004). Work-life balance and the software worker. *Human Resource Management Journal*, 14(2), 54-74.
- Tett, R. P., & Meyer, J. P. (1993). Job satisfaction, organizational commitment, turnover intention, and turnover: path analyses based on meta-analytic findings. *Personnel psychology*, 46(2), 259-293.
- Thanacoody, P. R., Bartram, T., & Casimir, G. (2009). The effects of burnout and supervisory social support on the relationship between work-family conflict and intention to leave: A study of Australian cancer workers. *Journal of Health, Organisation and Management*, 23(1), 53-69.
- Uddin, M. J., & Rahman, M. M. (2014). Measurement of Employees' Job Satisfaction on HRM Practices of Commercial Banks in Bangladesh. In *Proceedings of 11th Asian Business Research Conference, BIAM Foundation, Dhaka, Bangladesh*.
- Ugwu, L. I., & Agbo, A. A. (2010). Exploring the role of social support, work/family conflict, and gender-role ideology on burnout in a Nigerian sample. *African Journal for the Psychological Study of Social Issues*, 13(1) Retrieved from: <https://www.ajol.info/index.php/ajpssi/article/view/60747>.
- Voydanoff, P. (2014). *Work, family, and community: Exploring interconnections*. Psychology Press.
- Wayne, J. H., Musisca, N., & Fleeson, W. (2004). Considering the role of personality in the work-family experience: Relationships of the big five to work-family conflict and facilitation. *Journal of vocational behavior*, 64(1), 108-130.
- Yang, L. Q., Spector, P. E., Sanchez, J. I., Allen, T. D., Poelmans, S., Cooper, C. L., Lapiere, L. M., O'Driscoll, M. P., Abarca, N., Alexandrova, M., & Antoniou, A. S. (2012). Individualism-collectivism as a moderator of the work demands-strains relationship: A cross-level and cross-national examination. *Journal of International Business Studies*, 43(4), 424-443.
- Yildirim, D., & Aycan, Z., (2008). Nurses' work demands and work-family conflict: A questionnaire survey. *International journal of nursing studies*, 45(9), 1366-1378.
- Zeffane, R., Ibrahim, M. E., & Al Mehairi, R., (2008). Exploring the differential impact of job satisfaction on employee attendance and conduct: The case of a utility company in the United Arab Emirates. *Employee Relations*, 30(3), 237-250.